

Health Insurance Rate Review Division
 Arkansas Insurance Department
 1200 West 3rd Street, Suite 201
 Little Rock, AR 72201-1904

**REQUEST FOR PROPOSAL
 FOR
 INTERGOVERNMENTAL TECHNICAL SERVICES CONTRACT**

Technical Services Contract Number: RR-120142	Buyer: Lowell Nicholas
Service: All Payer Claims Database Data Center	Date: December 16, 2013
Agency: Arkansas Insurance Department Health Insurance Rate Review Division	Proposal Opening Date: January 20, 2014
Service Location: Little Rock, AR	Proposal Opening Time: 2:00 PM CST

PROPOSALS WILL BE ACCEPTED UNTIL THE TIME AND DATE SPECIFIED ABOVE. THE PROPOSAL ENVELOPE INCLUDING THE OUTSIDE OF OVERNIGHT PACKAGES **MUST** BE SEALED AND SHOULD BE PROPERLY MARKED WITH THE PROPOSAL NUMBER, DATE AND HOUR OF PROPOSAL OPENING AND RESPONDER'S RETURN ADDRESS. IT IS NOT NECESSARY TO RETURN "NO BIDS." RESPONDERS ARE RESPONSIBLE FOR DELIVERY OF THEIR BID DOCUMENTS TO THE ARKANSAS INSURANCE DEPARTMENT (AID) PRIOR TO THE SCHEDULED TIME FOR OPENING OF THE PARTICULAR BID. WHEN APPROPRIATE, RESPONDERS SHOULD CONSULT WITH DELIVERY PROVIDERS TO DETERMINE WHETHER THE BID DOCUMENTS WILL BE DELIVERED TO THE AID OFFICE STREET ADDRESS PRIOR TO THE SCHEDULED TIME FOR BID OPENING. DELIVERY PROVIDERS, USPS, UPS, AND FEDEX DELIVER MAIL TO OUR STREET ADDRESS ON A SCHEDULE DETERMINED BY EACH INDIVIDUAL PROVIDER. THESE PROVIDERS WILL DELIVER TO OUR OFFICES BASED SOLELY ON OUR STREET ADDRESS.

Proposal Delivery Address	Proposal Opening Location
<p>MAILING ADDRESS:</p> <p>Arkansas Insurance Department Health Insurance Rate Review Division 1200 West 3rd Street, Suite 201 Little Rock, AR 72201-1904 TELEPHONE NUMBER: 501-683-3638</p>	<p>BID OPENING LOCATION:</p> <p>Arkansas Insurance Department Health Insurance Rate Review Division 1200 West 3rd Street, Suite 201 Little Rock, AR 72201-1904 ATTN: Lowell Nicholas, Deputy Commissioner</p>

**HEALTH INSURANCE RATE REVIEW DIVISION - ARKANSAS INSURANCE DEPARTMENT
REQUEST FOR PROPOSAL**

Company Name:

Name of Authorized Company Official:

Title:

Address:

Telephone Number:

Fax Number:

E-Mail Address:

Signature:

(USE INK ONLY; UNSIGNED PROPOSALS WILL NOT BE CONSIDERED)

IDENTIFICATION:

• Federal employer ID Number

• Social Security Number

FAILURE TO PROVIDE TAXPAYER IDENTIFICATION NUMBER MAY RESULT IN PROPOSAL REJECTION

Business Designation
(*check one*)

Individual

Sole Proprietorship

Public Service Corp

Partnership

Corporation

Government/ Nonprofit

General	All Payer Claims Database/ Data Center
Type of	Fixed Price
Buyer:	Lowell Nicholas, Deputy Commissioner

**HEALTH INSURANCE RATE REVIEW DIVISION - ARKANSAS INSURANCE DEPARTMENT
REQUEST FOR PROPOSAL**

SECTION 1: GENERAL INFORMATION..... 5

- 1.1 INTRODUCTION5
- 1.2 ISSUING OFFICE5
- 1.3 TERM OF THE CONTRACT.....6
- 1.4 DEFINITION OF TERMS6
- 1.5 ITSC FORMAT.....8
- 1.6 CONTRACT INFORMATION.....8
- 1.7 RESERVATION.....9
- 1.8 COST OF PROPOSALS9
- 1.9 TERMS AND CONDITIONS OF PROPOSAL9
- 1.10 PROPRIETARY INFORMATION.....10
- 1.11 STATEMENT OF LIABILITY10
- 1.12 AWARD RESPONSIBILITY10
- 1.13 PUBLICITY.....10
- 1.14 INDEPENDENT PRICE DETERMINATION.....10
- 1.15 WARRANTY11
- 1.16 CONFIDENTIALITY11
- 1.17 TERMINATION OF CONTRACT11
- 1.18 NEGOTIATIONS11
- 1.19 INTELLECTUAL PROPERTY.....11
- 1.20 ANTICIPATED PROCUREMENT TIMETABLE.....11

SECTION 2: OVERVIEW..... 13

- 2.1 AUTHORITY13
- 2.2 BACKGROUND14
- 2.3 ELIGIBILITY TO BID.....16

SECTION 3: SCOPE OF WORK..... 16

- 3.1 PROJECT OVERVIEW.....16
- 3.2 ASSUMPTIONS17
- 3.3 POLICY AND PROGRAM DEVELOPMENT MINIMUM REQUIREMENTS.....18
- 3.4 DATA MANAGEMENT MINIMUM REQUIREMENTS22
- 3.5 SUSTAINABILITY MINIMUM REQUIREMENTS27

**HEALTH INSURANCE RATE REVIEW DIVISION - ARKANSAS INSURANCE DEPARTMENT
REQUEST FOR PROPOSAL**

3.6 PROJECT MANAGEMENT MINIMUM REQUIREMENTS 27

3.7 MILESTONE SCHEDULE..... 28

SECTION 4: PROPOSAL SUBMISSION..... 28

4.1 PROPOSAL FORMAT 28

4.2 TECHNICAL PROPOSAL..... 30

4.3 COST PROPOSAL..... 36

**HEALTH INSURANCE RATE REVIEW DIVISION - ARKANSAS INSURANCE DEPARTMENT
REQUEST FOR PROPOSAL**

SECTION 1: GENERAL INFORMATION

1.1 INTRODUCTION

The Health Insurance Rate Review Division (HIRRD) of the Arkansas Insurance Department (AID) received grant funding from the US Department of Health and Human Services (HHS), Centers for Medicare & Medicaid Services (CMS), Center for Consumer Information and Insurance Oversight (CCIIO) as part of The Health Insurance Rate Review Grant Program – *Grants to States to Support Health Insurance Rate Review and Increase Transparency In Health Care Pricing, Cycle III*. HIRRD has allocated a substantial portion of this Cycle III grant to a Data Center to establish an All Payer Claims Database (APCD) within the State of Arkansas. HIRRD intends to contract with a single entity to provide all required services and technical capacity to design, implement, and maintain operations of a statewide APCD.

An APCD is a large-scale database that systematically collects health care claims data from a variety of payer sources¹ including medical, dental, provider, and pharmacy claims data from private payers (e.g. commercial insurers) and public payers such as Medicare and Medicaid. With more than a dozen states having started to implement APCDs, these data centers are becoming an emerging data source for multiple stakeholders to understand health care costs, utilization, access, and quality. The Contractor solicited in this (ITSC) Request for Proposal will provide professional services for planning, stakeholder engagement, public education, data collection, data consolidation, data warehousing, quality assurance, secure storage, analysis, reporting, and sustainability for the Arkansas APCD.

In compliance with restrictions contained in the ACA and the terms of the Cycle III grant, a contract may be awarded only to an entity meeting specific initial requirements. This ITSC will require proposals to demonstrate that the submitter meets the definition of a Qualified Bidder. The Responder must demonstrate that it meets the ACA's definition of a Medical Reimbursement Data Center, including the definitions in ACA §2794(c)(1)(C)) and the Cycle III Grant Terms and Conditions in order to be eligible for consideration. Elements of the federal definition include but are not limited to the following: status as an academic institution or nonprofit organization; demonstrated expertise in health care claims data collection and analysis; and freedom from conflicts of interest. If an organization or entity meets minimum standards for a Qualified Bidder, HIRRD will evaluate the Qualified Bidder's full technical proposal. HIRRD will not evaluate proposals submitted by entities other than Qualified Bidders. The total award shall not exceed \$1.7 million.

1.2 ISSUING OFFICE

The issuing officer is the sole point of contact for this ITSC. Responders must direct questions or requests for clarification regarding matters related to this ITSC to Deputy Commissioner of the AID and Rate Review Director Lowell Nicholas at Lowell.nicholas@arkansas.gov. Responders must submit written questions to the issuing officer by the date listed in this solicitation. All questions should be marketed "Questions" and the ITSC number should be indicated.

¹ All Payer Claims Databases in Public Health and Medicaid: A Fact Sheet, 2010, APCD Council, National Association of Health Data Organizations (NAHDO)

**HEALTH INSURANCE RATE REVIEW DIVISION - ARKANSAS INSURANCE DEPARTMENT
REQUEST FOR PROPOSAL**

The issuing office will post answers to questions on the AID/HIRRD website. Accordingly, reliance on information received other than from the issuing office is at the Responder’s own risk. For technical information related matters, RESPONDERS may email the buyer.

Issuing Office
Arkansas Insurance Department Health Insurance Rate Review Division ATTN: Lowell Nicholas, Deputy Commissioner 1200 West 3 rd Street, Suite 201 Little Rock, AR 72201-1904 Email: Lowell.nicholas@arkansas.gov

1.3 TERM OF THE CONTRACT

HIRRD will award the winning responder an 18-month contract. In the event the State no longer needs the service or commodity specified in the contract or purchase order due to program changes, changes in laws, rules or regulations, relocation of offices, or lack of appropriated funding, the State may cancel the contract or purchase order by giving the contractor written notice of such cancellation 30 days prior to the date of cancellation.

1.4 DEFINITION OF TERMS

This section of the ITSC provides definitions and explanations of appropriate acronyms and terms relative to this ITSC.

APCD	All Payer Claims Database, a large-scale database that systematically collects and aggregates medical, dental, provider, and pharmacy claims data from private payers (e.g. commercial insurers) and public payers such as Medicare and Medicaid ²
AID	Arkansas Insurance Department, the purpose of which is to serve and protect the public interest by the equitable enforcement of the state’s laws and regulations affecting the insurance industry
Amendment	An amendment is used when information in the ITSC has been changed since the original posting
CCIIO	The Centers for Medicare & Medicaid Services’ Center for Consumer Information and Insurance Oversight (CCIIO), part of the U.S. Department of Health & Human Services (DHHS), provides national leadership in setting and enforcing standards for health insurance that promote fair and reasonable practices to ensure that affordable, quality health coverage is available to all Americans.

² All Payer Claims Databases in Public Health and Medicaid: A Fact Sheet, 2010, APCD Council, National Association of Health Data Organizations (NAHDO)

**HEALTH INSURANCE RATE REVIEW DIVISION - ARKANSAS INSURANCE DEPARTMENT
REQUEST FOR PROPOSAL**

Claims	The set of files submitted by Commercial Payers containing detailed information about member eligibility, medical services prescription drugs and other services provided through a plan of health insurance or its equivalent.
CMS	The Center for Medicare and Medicaid Services is the federal agency that runs the Medicare program and works with the State to run Medicaid.
Commercial Payers	Entities that provide a plan of comprehensive medical insurance coverage to Arkansas residents.
Contract	The fully executed, written agreement between the State of Arkansas/Arkansas Insurance Department and the Contractor chosen as a result of this ITSC, which includes the scope of services and cost
Contractor	Individual or company whose Proposal has been accepted by State of Arkansas/Arkansas Insurance Department and is awarded a fully executed, written Contract
Data Center	According to ACA §2794(c)(1)(C)) and the Cycle III Grant Terms and Conditions, a Data Center is an academic institution or nonprofit organization with demonstrated expertise in health care claims data collection and analysis free from conflicts of interest.
HIRRD	Health Insurance Rate Review Division of the Arkansas Insurance Department
HMO	Health Maintenance Organization
ITSC	Intergovernmental Technical Services Contract [State of Arkansas] (R1:19-11-251. Intergovernmental Agreements)
Proposal	A formal offer submitted in response to this ITSC solicitation.
Qualified Bidder	An academic or non-profit organization that meets all components of federal definitions of a Medical Reimbursement Data Center, as well as any clarifying guidance issued by CCIIO, and any other criteria, as determined solely by HIRRD.
Responder*	Individual or company that intends to submit a proposal with the desire of being awarded a Contract with State of Arkansas/Arkansas Insurance Department for this project
SHARE	State Health Alliance for Records Exchange (Arkansas OHIT).
Subcontractor	A person or business that will carry out a portion of the work for the Responder, as part of the project
System	Any and all processes, applications, software, hardware and parts thereof that produce the desired product

**HEALTH INSURANCE RATE REVIEW DIVISION - ARKANSAS INSURANCE DEPARTMENT
REQUEST FOR PROPOSAL**

1.5 ITSC FORMAT

Any statement in this document that contains the word “must” or “shall” or “will” means that compliance with the intent of the statement is mandatory, and failure by the respondent to satisfy that intent will cause the proposal to be rejected. It is recommended that offeror respond to each item or paragraph of the ITSC in sequence. Items not needing a specific Responder statement may be responded to by concurrence or acknowledgement; no response will be interpreted as an affirmative response or agreement to the State conditions. Reference to handbooks or other technical materials as part of a response must not constitute the entire response and respondent must identify the specific page and paragraph being referenced.

1.6 CONTRACT INFORMATION

The State of Arkansas may not contract with another party:

- A. To indemnify and defend that party for any liability and damages. However, the agency may agree to hold the other party harmless from any loss or claim resulting directly from and attributable to the State’s use or possession of equipment or software and reimburse that party for the loss caused solely by the State’s uses or possession.
- B. Upon default, to pay all sums to become due under a contract
- C. To pay damages, legal expenses or other costs and expenses of any party
- D. To continue a contract once the equipment has been repossessed
- E. To conduct litigation in a place other than Pulaski County, Arkansas
- F. To agree to any provision of a contract which violates the laws or constitution of the State of Arkansas

A party wishing to contract with the State of Arkansas should:

- A. Remove any language from its contract which grants to it any remedies other than:
 - 1. The right to possession
 - 2. The right to accrued payments.
 - 3. The right to expenses of de-installation.
 - 4. The right to expenses of repair to return the equipment to normal working order, normal wear and tear excluded.
 - 5. The right to recover only amounts due at the time of repossession and any unamortized nonrecurring cost as allowed by Arkansas Law
- B. Include in its contract that the laws of the State of Arkansas govern the contract
- C. Acknowledge that contracts become effective when awarded by the agency

1.7 RESERVATION

This ITSC does not commit the agency to award a contract, to pay costs incurred in the preparation of a proposal in response to this request, or to procure or contract for any service. The State reserves the right to accept or reject, in part or in its entirety, any or all proposals received as a result of the ITSC, if it is in the best interest of the State to do so.

**HEALTH INSURANCE RATE REVIEW DIVISION - ARKANSAS INSURANCE DEPARTMENT
REQUEST FOR PROPOSAL**

1.8 COST OF PROPOSALS

Costs incurred in preparation of proposals are solely the responsibility of the RESPONDERS. HIRRD will provide no reimbursements for such costs. Costs associated with any oral presentations to HIRRD will be the responsibility of the Responder and may not be billed to the HIRRD. Oral presentations may only be made at the request of the HIRRD.

1.9 TERMS AND CONDITIONS OF PROPOSAL

To be considered, Responders must include as part of their proposal all of the provisions of the ITSC.

- A. The Contractor shall at all times observe and comply with federal and State laws, local laws, ordinances, orders, and regulations existing at the time of or enacted subsequent to the execution of this contract which in any manner affect the completion of the work. The Contractor and surety shall indemnify and save harmless the Agency and all its officers, representatives, agents, and employees against any claim or liability arising from or based upon the violation of any such law, ordinance, regulation, order or decree by an employee, representative, or subcontractor of the Contractor. The contractor and subcontractor shall comply with Arkansas Act 954 of 1977.
- B. In accordance with federal regulation, the contractor agrees to retain all pertinent records for five (5) years after final payment is made under this contract or any related subcontract. In the event any audit, litigation or other action involving these records is initiated before the end of the five (5) year period, the contractor agrees to retain these records until all issues arising out of the action are resolved or until the end of the five (5) year period, whichever is later.
- C. The Contractor will grant access to its records upon request by state or federal government entities or any of their duly authorized representatives. Access will be given to any books, documents, papers or record of the Contractor which are related to any services performed under the contract. The Contractor additionally consents that all subcontracts will contain adequate language to allow the same guaranteed access to the record of subcontractors.
- D. Order of Precedence. In the event of any conflict or inconsistency in the definition or interpretation of any word, responsibility, service, time schedule, requirements, specifications or tasks in this agreement, said conflict or inconsistency shall be resolved according to the following priority:
 - Technical Services Contract Award
 - Responder proposal

**HEALTH INSURANCE RATE REVIEW DIVISION - ARKANSAS INSURANCE DEPARTMENT
REQUEST FOR PROPOSAL**

1.10 PROPRIETARY INFORMATION

Proprietary information submitted in response to this Technical Services Contract will be processed in accordance with applicable State of Arkansas procurement procedures. Proposals and documents pertaining to the Technical Services Contract become the property of the State and shall be open to public inspection subsequent to proposal opening. It is the responsibility of the Responder to identify all proprietary information. **The Responder should submit one complete electronic copy of the proposal, preferably in PDF format, from which any proprietary information has been removed, i.e. a redacted copy.** The redacted copy should reflect the same pagination as the original and show the empty space from which information was redacted. Except for the redacted information, the redacted electronic copy must be identical to the original hard copy. The redacted electronic copy will be open to public inspection under the Freedom of Information Act (FOIA) without further notice to the Responder. If you do not send a redacted electronic copy your entire proposal will be open to public inspection with the exception of financial data (other than pricing). If the State of Arkansas deems redacted information to be subject to the FOIA, the Responder will be contacted prior to the release of this information.

1.11 STATEMENT OF LIABILITY

The State will demonstrate reasonable care, but at no time will the State be responsible for or accept liability for any Responder-owned items.

1.12 AWARD RESPONSIBILITY

The agency will be responsible for award and for administration of any resulting contract.

1.13 PUBLICITY

News releases, or any release of information in a public manner including but not limited to social media, pertaining to the Technical Services Contract or the services, study, data or project to which it relates will not be made without prior written approval of the agency, and then only in accordance with the explicit written instructions from agency. No results of the program are to be released publicly without prior written approval from the agency, and then only to persons designated.

1.14 INDEPENDENT PRICE DETERMINATION

By submission of his/her proposal, the responder certifies, and in the case of a joint proposal, each party thereto certifies as to its own organization, that in connection with this proposal: the prices in the proposal have been arrived at independently, without collusion and that no prior information concerning these prices has been received from or given to a competitive company.

If there is sufficient evidence of collusion to warrant consideration of this proposal by the Office of the Attorney General, all responders should understand that this paragraph might be used as a basis for litigation.

**HEALTH INSURANCE RATE REVIEW DIVISION - ARKANSAS INSURANCE DEPARTMENT
REQUEST FOR PROPOSAL**

1.15 WARRANTY

The Responder must warrant that all services and any other items provided by the Responder in conjunction with this ITSC will be performed at the level specified herein Responder shall, at his/her expense remedy all such defects in performance.

1.16 CONFIDENTIALITY

The Responder shall be bound to confidentiality of any information of which its employees may become aware during the course of performance for the contracted task. Consistent and/or uncorrected breaches of confidentiality may constitute grounds for cancellation of the contract.

1.17 TERMINATION OF CONTRACT

In the event the State no longer needs the service or commodity specified in the contract or purchase order due to program changes; changes in laws, rules, or regulations; relocation of offices; or lack of appropriated funding, the State may cancel the contract or purchase order by giving the contractor written notice of such cancellation thirty (30) days prior to the date of cancellation. Upon receipt of notice of termination, the contractor shall be paid the following:

- At the contract price(s) for completed service to and acceptance by the State.
- At a price mutually agreed by the contractor and State for partially completed services.

1.18 NEGOTIATIONS

As provided in this request for proposal and under regulations, discussions may be conducted with responsible responders who submit proposal(s) determined to be reasonably susceptible of being selected for award for the purpose of obtaining clarification of proposal response and negotiation for best and final offers.

1.19 INTELLECTUAL PROPERTY

All records and data pertaining to the contract will remain the property of the HIRRD. Upon expiration or termination of contract, in order to ensure orderly turnover in the event another provider is selected or HIRRD takes over preparation, the contractor shall turn over the complete operation within sixty (60) days.

1.20 ANTICIPATED PROCUREMENT TIMETABLE

The following timetable is anticipated for the procurement process. All times refer to local time in Little Rock, Arkansas (CST).

ITSC Request for Proposal Issued	December 13, 2013
Deadline Date for Receipt of Written Questions	December 20, 2013
Answers Posted on HIRRD Website	January 6, 2014
Opening Date and Time/Receipt of Proposals 2:00 pm	January 20, 2014
Finalists Invited for Presentation	January 29, 2014

**HEALTH INSURANCE RATE REVIEW DIVISION - ARKANSAS INSURANCE DEPARTMENT
REQUEST FOR PROPOSAL**

Presentation by Selected Finalists (Little Rock)	February 10, 2014
Notice of Award	February 24, 2014
Expected Contract Start Date	April 1, 2014

**HEALTH INSURANCE RATE REVIEW DIVISION - ARKANSAS INSURANCE DEPARTMENT
REQUEST FOR PROPOSAL**

SECTION 2: OVERVIEW

2.1 AUTHORITY

The Arkansas Insurance Department (AID) serves and protects the public interest by the equitable enforcement of the state's laws and regulations affecting the insurance industry, with its primary mission consumer protection through insurer solvency. AID has primary regulatory authority over commercial health insurance carriers including individual, small group plans, and Health Maintenance Organizations (HMOs).

In September 2013, AID's Health Insurance Rate Review Division (HIRRD) received grant funding from the US Department of Health and Human Services (HHS), Centers for Medicare & Medicaid Services (CMS), Center for Consumer Information and Insurance Oversight (CCIIO) as part of The Health Insurance Rate Review Grant Program – *Grants to States to Support Health Insurance Rate Review and Increase Transparency In Health Care Pricing, Cycle III*. This federal Rate Review grant program resulted from the passing of the Patient Protection and Affordable Care Act (ACA), which includes a wide variety of provisions designed to promote accountability, affordability, quality, and accessibility in the health care system.

Section 2794(a) of the ACA requires the Secretary of HHS, in conjunction with states, to establish a process for the annual review of health insurance premiums to protect consumers from unreasonable rate increases. Section 2794(b) specifies that the process established by the Secretary "shall require health insurance issuers to submit to the Secretary and the relevant State a justification for unreasonable premium increases prior to the implementation of the increase," and that "such issuers shall prominently post such information on their Internet websites." The ACA directs the Secretary to "ensure public disclosure of information on such increases and justifications for all health insurance issuers." In addition, section 2794(c) directs the Secretary to carry out a program to award grants to states that enables them to accomplish the following: establish or enhance rate review programs; help states to provide data to regarding trends in rate increases as well as recommendations regarding plan participation in state-based Exchanges; and establish "Data Centers" that collect, analyze, and disseminate health care pricing data to the public.

According to CMS, a Data Center, established under subsection (c)(1)(C) of section 2794, must adhere to the following:

- develop fee schedules and other database tools that fairly and accurately reflect market rates for medical services and the geographic differences in those rates;
- use the best available statistical methods and data processing technology to develop such fee schedules and other database tools;
- regularly update such fee schedules and other database tools to reflect changes in charges for medical services;
- make health care cost information readily available to the public through an Internet website that allows consumers to understand the amounts that health care providers in their area charge for particular medical services; and
- Regularly publish information concerning the statistical methodologies used by the center to analyze health charge data and make such data available to researchers and policy makers.

HEALTH INSURANCE RATE REVIEW DIVISION - ARKANSAS INSURANCE DEPARTMENT REQUEST FOR PROPOSAL

Subcontracts for any aspect of data management, including but not limited to data intake, storage, production, analysis, reporting, and production of other outputs, in excess of \$100,000 are subject to prior review and approval by HIRRD. Such requests shall be accompanied by a justification describing the reasons that this particular subcontract is required. Furthermore, if the subcontract is with a for-profit or out-of-state entity, the Contractor shall describe the unique qualifications of the subcontractor that cannot be provided by a non-profit or Arkansas based legal entity. In addition, the Contractor shall assume all risk to the project schedule resulting from the time needed for HIRRD to review the contract.

2.2 BACKGROUND

HIRRD has allocated a substantial portion of its Cycle III grant to select a Data Center to operate and manage the Arkansas All Payer Claims Database (APCD). HIRRD is issuing this ITSC to obtain the services of a single Contractor to serve as the Data Center to plan, develop, implement, maintain, and sustain the Arkansas APCD. An APCD is a large-scale database that systematically collects health care claims data from a variety of payer sources³ including medical, dental, provider, and pharmacy claims data from private payers (e.g. commercial insurers) and public payers such as Medicare and Medicaid. With more than a dozen states having started to implement APCDs, these data centers are becoming an emerging data source for multiple stakeholders to understand health care costs, utilization, access, and quality.

Under HIRRD's oversight and approval, the Contractor will be responsible for the professional services necessary for APCD planning, stakeholder engagement, and public education. The Contractor will work diligently to optimize the voluntary data submission in the first year, and will plan the orderly transition to a comprehensive state-mandated data submission process in the second year.

The Contractor must provide the technical and project management necessary for data collection, data consolidation, data warehousing, quality assurance, secure storage, analyses, linkage to other datasets, and reporting. The Contractor will also be responsible for developing an acceptable sustainability plan for the APCD beyond federal funding.

The establishment of the Arkansas APCD will build upon the State's existing data collection initiatives. For example, the Health Data Initiative (HDI) was established by Arkansas Act of 1035 of 2003 which grants the Arkansas Center for Health Improvement (ACHI) voluntary access to data sources "if agreed to by state agencies responsible for maintaining requested data sources." The use of data allowed under this act is limited to research-based studies supporting Arkansas health policy officials. These include public health databases, health care utilization data, financial data related to the procurement of health or health care related services, data supplied as part of mandated reporting requirements to state agencies by entities, data collected and maintained under the State Health Data Clearinghouse Act of 1995, and other data sources supported and maintained with state funds.

³ All Payer Claims Databases in Public Health and Medicaid: A Fact Sheet, 2010, APCD Council, National Association of Health Data Organizations (NAHDO)

**HEALTH INSURANCE RATE REVIEW DIVISION - ARKANSAS INSURANCE DEPARTMENT
REQUEST FOR PROPOSAL**

The State Health Data Clearinghouse Act 670 of 1995 also granted authority to the Arkansas Department of Health for data collection to support research and aggregate statistical reporting; price and quality information about Arkansas hospitals; and reporting to the Governor and various committees.

The Advanced Health Information Network created by Arkansas Blue Cross and Blue Shield is a communication tool to connect hospitals, physicians, and payers to electronically transmit and receive clinical, administrative, and financial data. AHIN provides both member and provider portals and access to eligibility, claims, payment, and pharmacy data, as well as pre-authorization information.

The Arkansas Insurance Marketplace

Three (3) insurance carriers provide most of the individual and small group coverage for the state of Arkansas. They include USable Mutual Insurance Company (Arkansas Blue Cross Blue Shield), United Health Care Insurance Company, and QCA Health Plan Inc. (QualChoice). While there are many more companies that provide some type of health insurance in the state of Arkansas, many of these do not provide comprehensive health insurance. Instead, they provide limited services such as hospital indemnity, supplemental care, dental, or specified disease, essential core care, or accident benefit care.

In the individual health insurance market, the largest health insurer in Arkansas has over 65% of the market. Neighboring states tend to be somewhat more competitive by this measure with the largest insurer’s share of the market as follows: Louisiana 73%, Oklahoma 59%, Texas 56%, Mississippi 54%, Tennessee 36%, and Missouri 32%.⁴ In the small group insurance market, the largest insurer in Arkansas has over 51 % of the market. Arkansas is right in the middle of its neighbors; the largest insurer’s share of the market is as follows: Louisiana 80%, Mississippi 80%, Tennessee 70%, Oklahoma 46%, Missouri 42%, and Texas 40%

Table 1 provides a breakdown of covered lives in Arkansas:

TABLE 1: Estimated Insurance Coverage in Arkansas (2012)	
Source of Coverage	Covered Lives
Commercially Insured	
<i>Large Group</i>	208,000
<i>Small Group</i>	137,000
<i>Individual</i>	118,000
Medicaid	776,000

⁴Kaiser Family Foundation. “How Competitive are State Insurance Markets?”

**HEALTH INSURANCE RATE REVIEW DIVISION - ARKANSAS INSURANCE DEPARTMENT
REQUEST FOR PROPOSAL**

Medicaid 'Private Option'	150,000
Medicare	552,000
Uninsured	531,000 (estimated)
Other* ⁵	453,000 (estimated)
<i>Estimated Total</i>	2,915,000

2.3 ELIGIBILITY TO BID

ACA law and Cycle III grant guidelines set forth certain minimum standards for the type of organization that can receive funds as a Data Center. A Qualified Bidder under this ITSC meets all of the following criteria:

- A. The entity submitting the bid is an **academic or non-profit** institution (ACA 2794(c)(1)(C));
- B. The entity submitting the bid has capacity to collect medical reimbursement information from health insurance issuers, to analyze and organize such information, and to make such information available to such issuers, health care providers, health researchers, health care policy makers, and the general public (ACA 2794(c)(1)(C));
- C. The entity submitting the bid is free of conflicts of interest through by-laws establishing that the center and all its members of its governing board are independent and free from conflict of interest to ensure that the center is not controlled or influence by and does not have any corporate relation to, any individual or entity that may make or receive payments for health care services based on the center's analysis of health care costs (ACA § 2794 (d)(2));
- D. The entity submitting the bid has demonstrated familiarity with Arkansas health carriers.

As noted previously, subcontracts for any aspect of data management, including but not limited to data intake, storage, production, analysis, reporting, and production of other outputs, in excess of \$100,000 are subject to prior review and approval by HIRRD.

SECTION 3: SCOPE OF WORK

3.1 PROJECT OVERVIEW

HIRRD is issuing this ITSC to procure a Data Center to establish the Arkansas APCD, the goals of which include, but are not limited to:

- 1) Providing increased transparency in healthcare spending and utilization
- 2) Measuring qualified health plan quality
- 3) Helping consumers make health care purchases

⁵ "Other" includes third party administered plans, federal employees, military, Indian Health Service and any other source of coverage not otherwise counted.

HEALTH INSURANCE RATE REVIEW DIVISION - ARKANSAS INSURANCE DEPARTMENT REQUEST FOR PROPOSAL

For the APCD, the Data Center will conduct policy and program development, including stakeholder engagement in order to build an open, transparent process for health system policy makers, providers and consumers; educate the public about the benefits of an APCD; and obtain guidance about major components of the APCD's design, implementation and reporting activities.

A key result of the stakeholder process will be the creation of a conceptual model for phased data collection strategy that successfully moves from a voluntary initiative to a fully participatory mandatory process.

The Contractor shall also develop a multi-phase APCD data collection plan that establishes a methodology and framework for collecting data during both voluntary and a mandatory data collection authority. This includes the creation of an APCD Data Submission Guide that contains submission formats and file layouts to promote standardized data collection. The Contractor will also execute data use agreements with carriers, and ensure there is a robust and valid data security policy and process in place.

Once the APCD is in operation, the Data Center will provide ongoing data warehousing and security, and will provide reports and custom datasets to a variety of users, including researchers, policy makers, and the public. HIRRD expects that the Data Center will collaborate with the Arkansas State Health Alliance for Records Exchange to establish the foundation for aligning clinical data with claims data providing diagnostic, utilization, and cost information. At a minimum, the Data Center must utilize the same methodologies as SHARE for Unique Member Identification and Unique Provider Identification.

The Arkansas APCD must be operational by May 2014. The database must be able to accept test data from submitters beginning June 2014, followed by acceptance of historic data by September 2014, and monthly data submissions beginning December 2014. The first Arkansas APCD reports must be available to the HIRRD no later than January 2015.

The Data Center will also be responsible for ongoing APCD project management, as well as the development of a sustainability plan for the ongoing operations of the APCD beyond Cycle III grant funds.

3.2 ASSUMPTIONS

The Bidder may use the following assumptions in developing its response.

- A. The Contractor is responsible for creating and implementing all data use agreements needed to collect and use data under a voluntary submission model, including any legal fees that may be required.
- B. HIRRD estimates that the total number of covered lives in the APCD per year under mandatory data collection is 2.3 million.
- C. The Data Center should plan for data feeds from six commercial carriers.
- D. The Contractor will accept data from Arkansas Medicaid that conforms to the APCD data specifications issued by the Data Center and/or will map and transform Medicaid data into the APCD format.

**HEALTH INSURANCE RATE REVIEW DIVISION - ARKANSAS INSURANCE DEPARTMENT
REQUEST FOR PROPOSAL**

- E. The Contractor will serve as the CMS-approved Medicare data custodian for data sets obtained through the CMS State Agency Request Program and must provide appropriate security and warehousing.
The Contractor must also develop processes to transform the Medicare data files into the APCD format specified in the DSG or as needed to create data for inclusion in APCD reports, as permitted under the CMS Data Use Agreement.
- F. The Contractor's data warehouse must be sufficiently large to accommodate three (3) calendar years of submitted files; the Data Center may archive older files. The Contractor's business intelligence tools and access portals must be scalable, accommodate data extracts for different types of users, and allow the extracts to expand to include new records as the APCD becomes more robust.

3.3 POLICY AND PROGRAM DEVELOPMENT MINIMUM REQUIREMENTS

A. STAKEHOLDER ENGAGEMENT – The Contractor shall:

- (1) Convene HIRRD-appointed stakeholders to provide advisory input and respond to Contractor's plans.
- (2) Engage representation from the following agencies and organizations, with approval of the Director of the HIRRD:
 - a) The Arkansas state agencies of: Department of Insurance, Department of Health & Human Services (DHS), Department of Health (DOH), Office of Health Information Technology (OHIT), Development Finance Authority EHB, the Department of Economic Development, and Community Health Centers of Arkansas.
 - b) A currently elected Arkansas State Representative and State Senator.
 - c) The Arkansas Surgeon General or designee; the Arkansas Attorney General or designee, the Chancellor of University of Arkansas Medical Systems (UAMS) or designee.
 - d) The Director of the newly formed Arkansas Health Insurance Marketplace
 - e) The Arkansas Medical Association, the Arkansas Hospital Association; the Arkansas Pharmacy Association; senior management representatives of at least two commercial health plan issuers based in Arkansas, a consumer organization (health care advocacy), health improvement organization; individual with knowledge of health care data security and privacy; and health care researcher.
- (3) Provide staff support to stakeholder group, which will transition to an 11-member APCD Governance Board on January 15, 2015. The APCD Governance Board membership will be appointed by the Governor of the State of Arkansas, and will convene at least monthly to consider strategies, agendas, work plans, and budgets.
- (4) Prepare the following documents or presentations for stakeholder discussion:
 - a) Acceptable de-identification process of carrier data
 - b) Role of the Data Center in providing APCD reports and data
 - c) Opportunities to leverage existing legal authority to collect APCD-type data, including an analysis of scope of collection; permitted data uses, and assessment of whether additional legislative authority is needed to achieve the goals of the APCD
 - d) Resources needed in all state agencies to maximize access and analysis of APCD data outputs in calendar years 2014-15
 - e) Innovative strategic plan to optimize voluntary data collection

**HEALTH INSURANCE RATE REVIEW DIVISION - ARKANSAS INSURANCE DEPARTMENT
REQUEST FOR PROPOSAL**

- f) Strategic plan for a mandatory data collection process during the first quarter of 2015
 - g) Principles for APCD operations
 - h) Principles of a data use policy under both voluntary and, after enactment, mandatory data submission requirements
 - i) Principles for linking APCD data with SHARE data and appropriate uses of the resultant files
 - j) Principles for a sustainability plan
 - k) Roll out of reports based on two “releases” during the initial contract term
- (5) Prepare and deliver quarterly reports to the Director of HIRRD and the Arkansas Insurance Commissioner describing its progress towards achieving the project’s goals.

B. MULTI-PHASE DATA COLLECTION PLAN – The Contractor shall:

- (1) Develop and deliver to HIRRD a plan to implement a transition from optimal voluntary data submission to mandatory data submission, including a set of action steps and processes.
- (2) Develop a specification (Data Submission Guide, or “DSG”) that contains submission formats and file layouts to promote standardized data collection.
 - a) The DSG shall be designed to best meet the state’s analytic needs and will be informed by input from stakeholders.
 - b) The structure and content of the DSG must recognize the expected transition from voluntary to mandatory data submission.
 - c) The Contractor may implement time-limited, carrier-by-carrier, data-element specific exceptions to facilitate data intake. The contractor must document the exception process and criteria for granting exceptions.
 - d) The Contractor shall advise data submitters in face-to-face meetings (if geographically practical), conference calls, and technical advisory bulletins.
 - e) The Contractor shall obtain all necessary permissions and tools to generate and implement the same Unique Person Identifier and the Unique Provider Identifiers as used in SHARE.
- (3) Conduct the following during Data Collection Phase One--Voluntary Data Submission:
 - a) Engage private carriers to establish voluntary data use agreements (upon start of the contract).
 - b) Develop pricing data sets that satisfy at least the following criteria.
 - (i) The data sets must include fair and accurate pricing and reimbursement data from providers or issuers in the State of Arkansas.
 - (ii) The data set must include a sufficiently representative subset of claims from the state in order to be useful to consumers, employers, researchers, and the general public when pricing prices.
 - c) Provide all services necessary for drafting and implementing data use agreements, including legal review, meetings with payers, and annual updates or renewals.
 - d) Ensure that data files submitted by commercial payers and Medicaid include:
 - (i) The SHARE-generated Unique Person Identifier for the individual OR
 - (ii) Sufficient information such that the Contractor may assign Unique Person Identifiers and Unique Provider Identifiers using the SHARE identifier methodology.

**HEALTH INSURANCE RATE REVIEW DIVISION - ARKANSAS INSURANCE DEPARTMENT
REQUEST FOR PROPOSAL**

- e) Inform commercial carriers about the specific projects for which the data will be used.
 - f) Obtain signed agreements from commercial payers and Arkansas Medicaid no later than May 2014.
 - g) Prepare and submit a request for Medicare data on behalf of HIRRD via the CMS State Agency Request Program; pay for the initial datasets and annual updates thereafter; serve as data custodian; apply SHARE identifiers; map to APCD formats; and incorporate the Medicare data into APCD reports, as permitted under the CMS Data Use Agreement.
- (4) Conduct the following to help transition to a Mandatory Data Collection Process:
- a) Provide analysis and research about options for mandatory submission.
 - b) Analyze state law and regulation to ascertain any impediments to health care data collection.
 - c) Survey other states' mandatory data collection process and shall prepare a summary based on national best practices.
 - d) Review the national best practices with stakeholders and present a final document to HIRRD no later than September 1, 2014, accompanied by a report describing the rationale for mandatory data collection; stakeholder input; public education materials; and a public education series of events. The report shall include a description of the specific meetings and stakeholder engagement activities that should occur during mandatory submission consideration. Upon acceptance of the report and community support plan, the Contractor shall conduct those approved activities on behalf of the APCD in late 2014 and early 2015.
- (5) Conduct the following upon transitioning to a mandatory submission process:
- a) Draft rules that direct payers to submit files conforming to the revised DSG by dates established in the Contractor's Strategic Plan in Section C.1.
 - b) Review the DSG to determine if any changes are needed, and conduct a process with stakeholders to prepare a DSG to include by reference in the rules/regulations
 - c) Prepare and present materials to stakeholders about the rules
 - d) Obtain, review and respond to public comment about the draft rules
 - e) Provide a final copy of the rules/regulations to HIRRD.
- (6) Conduct the following upon promulgation of rules:
- a) Prepare data collection systems to receive any additional or new data submissions
 - b) Ensure that data intake methodologies and quality reviews reflect higher levels of completeness and accuracy under mandatory requirements.
 - c) Implement a formal compliance process to result in high quality, credible data submissions.

C. PRIVACY AND SECURITY POLICY DEVELOPMENT - The Contractor shall:

- (1) Ensure that the APCD maintains the highest level of security at all phases of data collection, storage, and analysis including:
 - a) Compliance with the HIPAA Privacy Rule
 - b) Physical, administrative, technical, operational, and personnel data protection
- (2) Meet CMS requirements to serve as Custodian of Medicare files containing protected health information (PHI).
- (3) Provide public-facing descriptions of its privacy and security policies and procedures to inform stakeholders and patients about how data will be protected.

**HEALTH INSURANCE RATE REVIEW DIVISION - ARKANSAS INSURANCE DEPARTMENT
REQUEST FOR PROPOSAL**

- (4) Designate a single individual to act as the Security and Privacy Control Officer for this project, to be accountable for the implementation of all privacy and security measures, and for auditing security and encryption processes.
- (5) Develop a security plan for maintaining data security and preventing unauthorized disclosures of APCD data, including a breach notification process that is compliant with State and Federal rules, regulations, and statutes related to the unauthorized release of protected data.
- (6) Provide evidence of cyber-insurance for \$3,000,000 as of the first day that data may be collected; this policy shall remain in force for the duration of the contract, and in addition to general professional liability/errors and omissions coverage.

D. DATA INTAKE PLAN - The Contractor shall:

- (1) Develop methods and implementation strategy for a web portal with a Secure Socket Layer (SSL) web upload interface for data submitters to transmit and monitor data to the Contractor.
- (2) Utilize this portal to provide feedback on data quality back to the data submitters.
- (3) Execute an extract, transform, and load (ETL) process that supports high-volume imports of multiple data files, in multiple formats, and at rapid speeds.
- (4) Develop the following:
 - a) Protocol for testing and verifying the performance of the APCD intake processes and infrastructure, prior to the submission of test data from data submitters.
 - b) Protocol to implement and maintain encryption methods, including:
 - Methods that allow data submitters to encrypt files that will be transferred to the Contractor. This shall include a process for handling data files that are submitted without appropriate encryption, or data files that contain claims data subject to additional restrictions;
 - Methods that allow data files to be encrypted for storage, backup, and transfer.
 - Methods that allow certain identifiable data fields to be populated with encrypted values so that the true values are not known, and allow Contractor to decrypt these same fields for purposes specified by the HIRRD.
 - c) Protocol for the acceptance of test data from data submitters, and a process for how test data will be utilized to smooth submission of conforming data, as required.
 - d) Methods for receiving and storing Medicaid claims and encounter data from the Medicaid Management Information (MMIS) and a description of how this data will be accommodated in the data warehouse.
 - e) Methods for receiving and storing Medicare files from CMS including how this data will be accommodated in the data warehouse and incorporated into the APCD.
- (5) Implement the following privacy and security protocols:
 - (a) Provide encryption of data in motion and at rest in compliance with the HITECH Act. Contractor shall employ FIPS 140-2 compliant cryptographic controls in accordance with NIST Special Publication 800-52 and provide encryption of data at rest in accordance with NIST Special Publication 800-111
 - (b) Designate a single Security and Privacy Control Officer for this project.
 - (c) Implement and monitor the security plan as developed and approved
 - (d) Periodically test, assess, and update the security plan to assure that the highest industry standards related to privacy and security are being followed. If a separate hosting facility Subcontractor will not be used, conduct an annual security

**HEALTH INSURANCE RATE REVIEW DIVISION - ARKANSAS INSURANCE DEPARTMENT
REQUEST FOR PROPOSAL**

assessment, performed by an independent third-party security provider, to verify that the environment containing the APCD data is secure.

- (e) If using a hosting Subcontractor, provide description of annual reports and audits (including SOC reports Type 1 and Type 2) and the results of those reports
- (f) Maintain, and provide upon request, a data and systems security log that can be reviewed by an independent auditor.
- (g) Provide a single point of contact to provide assistance to all data submitters to resolve data transmission issues.
- (h) Provide role-based security and encryption of data in motion and at rest in compliance with the HITECH Act. Provide encryption of data during transmission employing FIPS 140-2 compliant cryptographic controls in accordance with NIST Special Publication 800-52. Provide encryption of data at rest in accordance with NIST Special Publication 800-111.
- (i) Adheres to prohibition from releasing or using data or information obtained in its capacity as the APCD Data Center for any purpose other than those authorized by HIRRD.
- (j) Implement and maintain criteria that will be invoked to ensure only conforming data is loaded into the data warehouse. Provide business rules for testing data at intake to data submitters.
- (k) Implement and maintain a process for providing one-on-one communications and technical assistance to data submitters, including:
 - (i) Meet or hold conference calls (as geographically practical) with commercial payers' technical staff to provide data submission tools/requirements and address any questions regarding data submission;
 - (ii) Hold regularly scheduled data submitters' meetings and maintain ongoing collaborative relationships with all data submitters;
 - (iii) Provide a single point of contact for problem solving and troubleshooting with data submitters to ensure timely solutions.
- (l) Implement and maintain the protocol for a web-based secure data transfer system to transmit, monitor, and provide feedback on data files from data submitters to the Contractor.
- (m) Implement the protocol for testing and verifying the performance of the intake capacity prior to submission of test data from data submitters.
- (n) Implement and maintain the protocol for accepting test data from submitters, based on approved protocol.
- (o) Provide reports as about data submission and conformance to specifications on a weekly basis during startup and monthly thereafter.
- (p) Contact non-compliant entities via written notice describing the reporting deficiency.
- (q) Re-evaluate data collection services periodically and propose improvements.

3.4 DATA MANAGEMENT MINIMUM REQUIREMENTS

E. DATA WAREHOUSING - The Contractor shall:

- (1) Provide secure storage separate from other activities, including segregated storage for Medicare Data
- (2) Build integrated claims and eligibility file structures

**HEALTH INSURANCE RATE REVIEW DIVISION - ARKANSAS INSURANCE DEPARTMENT
REQUEST FOR PROPOSAL**

- (3) Design and implement a methodology to “version” the claims and passing forward the latest or “final” iteration into the APCD dataset.
- (4) Use SHARE methodology, or cause data submitters to use SHARE methodology, to assign unique provider ID and build a master provider index unless otherwise available from SHARE
- (5) Assign geocodes, diagnostic condition categories, and other analytic flags and groupings.

F. DATA QUALITY - The Contractor shall:

- (1) Upon data submission, check all files for alignment with the DSG.
- (2) During production and warehousing, conduct additional data quality reviews, and will review and report on:
 - a) Month-to-month trends, variation, and consistency
 - b) Benchmarking using other data sources
 - c) claims lines per 1,000 covered lives
 - d) outliers
- (3) Provide ongoing feedback to data submitters and in reports to HIRRD

G. ANALYSIS AND REPORTS - The Contractor shall:

- (1) Issue reports and make data available based on stakeholder principles.
- (2) Develop the following “early” deliverables:
 - a) population-based cost and utilization reports by geographic area
 - b) average or median cost per type of procedure
 - c) data extracts to experienced researchers who may serve as “beta testers” of data quality
 - d) risk-adjusted population costs
- (3) Develop the following “later” deliverables:
 - a) provider specific cost and quality reporting; distribute preview reports and manage comments based on best practices and research
 - b) reports that provide assistance in choosing high value, high quality care
 - c) website and/or mobile apps to distribute information
 - d) public reporting plan based upon HIRRD approval

H. MINIMUM REQUIREMENTS FOR 3.4 DATA MANAGEMENT - The Contractor shall:

- (1) Develop a protocol for data aggregation and enhancement that supports desired reporting outputs, including:
 - a) A methodology for eliminating duplicate information due to claims resubmissions and the normal course of business (sometimes called “versioning” the claim.)
 - b) A description of the data model that will be used to develop analytic reports, with the goal of creating person-level longitudinal analyses; and,
 - c) The ability to track data by patient, provider, payer, episode of care, disease, and geography.
- (2) Develop a plan to replicate the methodology used by the Arkansas State Health Alliance for Records Exchange (SHARE) to assign unique patient identifiers to both historic and incoming monthly data such that an individual’s claims and eligibility is organized over time and across payers such that APCD records may be consistently and accurately linked to SHARE records.

**HEALTH INSURANCE RATE REVIEW DIVISION - ARKANSAS INSURANCE DEPARTMENT
REQUEST FOR PROPOSAL**

- (3) Provide evidence of reliability and accuracy of selected methodology prior to implementation.
- (4) Develop a plan to replicate the methodology used by the Arkansas State Health Alliance for Records Exchange to unique healthcare facility and provider identifiers, to allow aggregation of claims across payers such that APCD records may be consistently and accurately linked to SHARE records.
- (5) Provide evidence of reliability and accuracy of selected methodology prior to implementation.
- (6) Identify an industry standard tool or methodology for uniquely identifying claims that may be adjudicated multiple times.
- (7) Ensure the data warehouse reflects the most current adjudication for each claim and will provide the methodology for carriers that do not provide unique claim ID's.
- (8) Develop a protocol for ensuring that claims link to eligibility records and provider records.
- (9) Develop a protocol for maintaining eligibility records for all covered members and maintaining eligibility spans for those members as eligibility record updates are received on a monthly basis from data submitters.
- (10) Identify an industry standard tool or methodology for grouping patient claims into distinct episodes of care, and develop methods and implementation plan.
- (11) Identify an industry standard tool or methodology for grouping patient claims into distinct condition categories and relative risk groups, and develop methods and implementation plan.
- (12) Implement, maintain, and operate secure receipt, management, storage, authorized release and transmission of data, including a process for archiving original data submissions and data products provided to HIRRD
- (13) Implement, maintain, and operate secure backups and recovery of data.
- (14) Provide a description of the steps to be taken for disposing of defective or end-of-life hardware or media that contain data.
- (15) Implement, maintain, and operate an open, standards based architecture, with an API or web services framework.
- (16) Implement, maintain, and operate a standards based database that can be queried with SQL, such as MS SQL Server, Oracle, etc.
- (17) Provide the infrastructure and capability to aggregate claims across payers into distinct quarterly and annual data sets and provide documentation of the layout, format, and coding. The data sets may include, but are not be limited to:
 - a) Medical claims
 - b) Medical eligibility
 - c) Medical providers
 - d) Pharmacy claims
 - e) Integrated member and claims datasets to support creating reports at aggregated and subgroup levels. Examples of subgroups that could be required include: multiple demographic selection criteria; disease categories; procedure types; and/or specific providers.
- (18) Implement the plan developed and approved in for geo-coding claims and member eligibility files.
- (19) Provide and align APCD data with data derived from US Census files, for purposes of population reporting.

**HEALTH INSURANCE RATE REVIEW DIVISION - ARKANSAS INSURANCE DEPARTMENT
REQUEST FOR PROPOSAL**

- (20) Implement the plan developed and approved for providing the twice annual refreshed data extracts for use in analytics and reporting.

I. DATA QUALITY - The Contractor shall:

- (1) Develop a comprehensive data quality plan that includes at a minimum:
- a) A description of specific mechanisms that will be implemented to ensure high-quality, robust, and accurate data. This must include a comprehensive data quality monitoring and management strategy and a list of all quality checks performed on another, similar implementation.
 - b) A process for communicating data submission and data quality issues within Contractor's own team and with data submitters.
 - c) A process for documenting interactions with payers about whether files conform to data specifications and recording agreed-upon exemptions from specific submission requirements.
 - d) A process for regularly examining the data after versioning and assignment of unique member and patient identifiers, including benchmarking against historical patterns for the data submitter and other submitters, patterns of missing or incomplete reporting within files, and interfile consistency (e.g. every claim has a valid member record). Provide reports and feedback to the data submitter.
 - e) A process for reporting data submission and quality issues to HIRRD staff.
 - f) Develop a protocol for ensuring high-quality, robust benchmarking of APCD data against reliable sources of information about members, claims, utilization, and cost.
- (2) Implement and maintain the protocol for the comprehensive data quality plan
- (3) Provide a report to each data submitter, showing the detailed results of initial checks and quality assurance within 5 days of submittal, through the secure portal implemented in Section 3.4.
- a) The report must clearly indicate which files passed the validation process.
 - b) The report must include, but is not limited to, the submission date, the number of records processed, the validation status of each data file and element, and the specific reason that the data element failed validation, when applicable. Information provided to data submitters must be sufficient and clear enough for submitters to easily reconcile and resolve errors.
 - c) Error correction is the sole responsibility of the data submitter.
- (4) Maintain documentation of data submissions, including requests for and responses to requests for resubmissions; the contractor shall make such documentation available to HIRRD for monitoring data submitters' compliance.
- (5) Implement the process for exemptions to specific data element submission requirements (also known as "waivers").
- (6) Review data submitters' requests for waivers of data submission requirements and advise on the effect of such waivers on the analytic data quality.
- (7) Receive and review waivers or exemptions to requirements specific to a particular data element or file, review with HIRRD, and implement necessary changes to intake checks and quality reviews on a carrier-specific basis.
- (8) Develop documentation for inclusion in data users' dictionary.
- (9) Load data into a secure data warehouse and perform additional record level and statistical error checking as part of an overall quality assurance process.

**HEALTH INSURANCE RATE REVIEW DIVISION - ARKANSAS INSURANCE DEPARTMENT
REQUEST FOR PROPOSAL**

- (10) Provide quarterly reports on submitted/processed datasets to the APCD, regarding the quality, completeness, reliability, robustness, and limitations of the quarterly update.
- (11) Implement and test algorithms of unique patient identifiers according to the plan developed; always utilizing SHARE's Master Patient Index research and development.
- (12) Develop a master provider directory utilizing the Provider Data File as the source; this master provider directory must be supplemented with commercially available provider records; whenever possible, Contractor will link to these functions through SHARE.
- (13) Specify the limitations of implementing the unique identifiers and periodically re-evaluate the implementation plan and suggest improvements.
- (14) Implement the quality assurance and benchmarking plan developed and approved to monitor the completeness and credibility of the submitted and processed data.
- (15) Provide analysis of unexplained variations and provide guidance to data submitters as needed to improve data quality and accuracy.

J. ANALYSIS AND REPORTING - The Contractor shall:

- (1) Develop a protocol and timeline for geo-coding claims and member eligibility files, and aligning these geo-codes with census data to support population health analyses based on race and ethnicity.
- (2) Develop a protocol and timeline for providing refreshed, aggregated data extracts twice per year.
- (3) Develop, implement, maintain, and operate a data mart, accessible to a small group of business users, including five (5) authorized HIRRD or other state agency staff. This data mart must provide de-identified "limited data sets"; allowing for customized queries and methods for flexibly retrieving desired data through a secure portal.
- (4) Re-evaluate infrastructure and capabilities of the data mart periodically and propose improvements to HIRRD.
- (5) Implement and periodically test the grouping of patient claims into distinct episodes of care, based on approved protocol
- (6) Implement and periodically test the grouping of patient claims into distinct condition categories and relative risk groupers, based on approved protocol
- (7) Provide a full description of each analysis/data extract prepared, including a description of the data set, a data dictionary, a user's document and guide, and an FAQ.
- (8) Develop and implement process for producing custom reports and datasets upon request.
- (9) Re-evaluate this plan periodically and propose improvements.
- (10) Provide analytical processing tools that allow data to be further aggregated, and represented in tabular, graphical, and other instructive reporting formats.
- (11) Develop Version 1.0 reports and make available on web-based module that meet the following criteria:
 - a) Reports must be accessible and meaningful to public health and provider communities, and the general public.
 - b) Reports must support Rate Review projects as described in the Cycle III Grant Proposal.
- (12) Develop Version 1.5 reports and make available on web-based module.
 - a) These reports will expand on the number of procedures and visits documented in the Version 1.0 Reports and will refresh the cost information.
 - b) The contractor will make reports available on the web-based application.

**HEALTH INSURANCE RATE REVIEW DIVISION - ARKANSAS INSURANCE DEPARTMENT
REQUEST FOR PROPOSAL**

- (13) Establish capacity to link APCD data files with clinical data derived from SHARE and other state data files to support academic research projects.
- (14) Test potential linkages with other state health care information files to determine utility and added information derived from such linkages.
- (15) Establish capacity to produce new reports and analysis twice per year, according to a schedule and priorities determined by HIRRD and other stakeholders.

K. DATA RELEASE - The Contractor shall:

- (1) Design and implement a data release process consistent with HIPAA Privacy Rule and, when in place, state legislation.
- (2) Design de-identified and limited use data specifications; produce such files when APCD data submissions meet minimum standards identified during the data quality standards development process.
- (3) Convene a data release committee to review applications for consistency with the purposes of the Data use agreement during Phase One: Voluntary Data Submission or other process during Phase Two: Mandatory Data Submission and serve as a HIPAA Privacy Board. (An institutional review board review may be obtained in lieu of requiring a HIPAA Privacy Board review.)
- (4) Collect fees and distribute data or reports to approved users through secure methods.
- (5) Develop secure data transmission processes.

3.5 SUSTAINABILITY MINIMUM REQUIREMENTS - The Contractor shall:

- (1) Develop a plan to maximize ongoing financial support from sources other than state appropriations.
- (2) Estimate the value of current data purchases and forecast the potential volume of requests for APCD data.
- (3) Examine the opportunities for delivering data and reports (at appropriate levels of detail) through standard reports, custom reports, self-service tools, and subscriptions.
- (4) Identify the differences between opportunities available under voluntary data submission compared to mandatory data submission.
- (5) Examine other states' revenue opportunities from similar initiatives.
- (6) Develop a "straw man" pricing schedule and set of offerings, and obtain feedback from potential "buyers".
- (7) Prepare a recommendations report to HIRRD describing offerings, pricing and potential revenue, as well as costs of standing up different types of data delivery models and ongoing operation and maintenance.

3.6 PROJECT MANAGEMENT MINIMUM REQUIREMENTS - The Contractor shall:

- (1) Develop a protocol for assuring that the project stays on schedule, the desired outcomes are achieved, obstacles (and solutions) are quickly identified, and progress is reported to in a timely manner.
- (2) Submit draft and final version of the Project Plan.
- (3) Obtain HIRRD approval prior to implementing all items in the Project Plan.
- (4) Identify a Project Manager to oversee the project and serve as the single point of contact.
- (5) Hold regular project status meetings (at least 2 per month), and submit monthly written project status reports

**HEALTH INSURANCE RATE REVIEW DIVISION - ARKANSAS INSURANCE DEPARTMENT
REQUEST FOR PROPOSAL**

- (6) Identify project risks during the project planning phase and proposed mitigation strategies; monitor risks throughout the project lifecycle
- (7) Provide reports and documentation as needed for federal reporting
- (8) Document decisions and compile project history recording the rationale for such decisions; provide to HIRRD at least annually.
- (9) Provide any information, data, or technical assistance as perceived to be useful or that might be requested by HIRRD in order to improve ongoing collection, processing, consolidation, management, and reporting efforts.

3.7 MILESTONE SCHEDULE

All Proposals must conform to the following Milestone Schedule, and must reference this table in their proposed solutions.

Activity	Estimated Completion Date
Anticipated Contract Effective Date	April 1, 2014
Draft Project Plan (Task One)	April 30, 2014
Final Project Plan for Implementation	May 9, 2014
Data Warehouse Operational	June 15, 2014
Project “Kick-Off” with Carriers Completed	July 30, 2014
Test Data Submitted by Carriers	August 30, 2014
Historical Data (past 3 years) Submitted by Carriers	September 30, 2014
Year to Date Files Submitted by Carriers	October 30, 2014
Monthly Submission from Carriers Begin	November 15, 2014
Version 1.0 Reports Developed	January 15, 2015
Version 1.5 Reports Developed	April 15, 2015
Version 2.0 Reports Developed	June 15, 2015
Version 2.5 Reports Developed	October 15, 2015

SECTION 4: PROPOSAL SUBMISSION

4.1 Proposal Format

A. The Responder’s APCD Proposal must follow the following submission format:

- a) Proposals must be provided in a three-ring binder.
- b) Paper Size: 8.5 x 11 inches

**HEALTH INSURANCE RATE REVIEW DIVISION - ARKANSAS INSURANCE DEPARTMENT
REQUEST FOR PROPOSAL**

- c) Minimum font size: 11 point (except for footnotes, headers, or footers) single spaced
- d) Each page of the Proposal must include a page number and the number of total pages.
- e) Each proposal must identify the Responder name in the page footer.
- f) Tabs must separate each section of the Proposal.

B. Responders are required to submit:

- (1) Six (6) hard copies in binders organized in the order as specified above. Documents must be separated by tabbed dividers within the binder.
- (2) Three (3) soft copies on CD-ROM that will contain all documents (this is in addition to submission of hard copies of the proposal).

C. Proposals must adhere to the following outline and page limits and must not include items not identified here.

Proposal Section	Page Limit
Cover Page	2 pages
Table of Contents	2 pages
Evidence of Bidder’s Qualifications	2 Pages
Glossary of Terms and Abbreviations	2 pages
Insurance Requirements	2 pages
Executive Summary	2 pages
Assumptions	1 page
Minimum Standards for Proposal Consideration Narrative Response Company Financial Strength documents	3 pages
Minimum Requirements Narrative Response*** <i>In the Proposal, this section should be a high-level description of proposed methods and protocols for completing each requirement.</i>	20 pages
Data Model	1 page
Response to Business Continuity Capabilities	2 pages
Project Implementation Schedule	4 page
Organizational Capacity	10 pages, excluding resumes
APCD Sustainability	3 pages
Cost Proposal	2 pages

**HEALTH INSURANCE RATE REVIEW DIVISION - ARKANSAS INSURANCE DEPARTMENT
REQUEST FOR PROPOSAL**

4.2 TECHNICAL PROPOSAL

A. Cover Page

The first page of the Responder's Proposal must be a cover page that includes bidder name, contact person, address, telephone, fax, email address, and Federal Tax ID number.

B. Table of Contents

The Responder must provide a table of contents with corresponding page numbers related to its Proposal. The table of contents must conform to the outline provided in Section 4.2 Technical Proposal.

C. Minimum Standards for Proposal Consideration

- (1) Responder must demonstrate that they meet the minimum qualifications for Proposal consideration. This section must include a narrative response detailing the items found in 2.3 Eligibility to Bid.
- (2) In addition to the narrative response, Responder must provide one of the following to document the long-term financial strength and stability of the company:
 - (a) The firm's two most recent audited financial statements; and the firm's most recent un-audited, quarterly financial statements; or
 - (b) The firm's most recent income tax return. For example, either a copy of the IRS Form 1065, U.S. Return of Partnership Income of Schedule E (IRS form 1040) Supplemental Income and Loss, or IRS Form 1120, U.S. Corporation Income Return. These forms are typically submitted when a Data Manager does not have audited financial statements.
 - (c) Evidence of the organization's nonprofit status (501 c3), if applicable
 - (d) Disclosure of any potential conflict of interest and/or a statement attesting to no conflict of interest
 - (e) Physical address of Arkansas-based location
- (3) If Proposal is selected for further consideration, the Responder must provide an additional financial reference letter from its bank; that speaks to the financial reputation and history of the company.

D. Glossary of Terms and Abbreviations

The Responder must provide a glossary of all terms, acronyms, and abbreviations used in its Proposal.

E. Insurance Requirements

The Responder must describe their current insurance coverage for the following types of insurance: Cyber Insurance, General Liability, Professional Liability, Automobile, and Extended Coverage. Any Contract resulting from this ITSC will require that the Contractor obtain and maintain: comprehensive general liability insurance against all claims of bodily injury, death or property damage, in amounts of not less than \$250,000 per claim and \$2,000,000 per occurrence; professional liability insurance against all claims of error, omission, or negligent acts related to professional services to be provided, in amounts not than \$2,000,000 per each occurrence and in aggregate;

**HEALTH INSURANCE RATE REVIEW DIVISION - ARKANSAS INSURANCE DEPARTMENT
REQUEST FOR PROPOSAL**

Automobile liability insurance in an amount not less than \$1,000,000 and fire and extended coverage insurance covering all data and property which has been received from APCD data submitters, HIRRD, or purchased with funds provided for those purposes as part of this ITSC, in an amount not less than 80% of the whole replacement value of the property. The applicable insurance policies must name Arkansas Insurance Department as an additional insured under such policies, and professional liability insurance must specifically include coverage for data security and privacy risks (*i.e.*, cyber insurance). If Responder does not currently possess insurance adequate to the coverage required under this ITSC, Responder will be required to secure insurance as described above to be effective on the first day of the Contract term.

F. Executive Summary

- (1) The Responder shall provide, as a separate document, an executive summary of its Proposal. This document must not exceed three (3) pages and must provide an overview of the Responders proposed solution and services, its commitment to serving the interests of the Arkansas APCD, and an understanding of the possible challenges in executing the project. The executive summary must contain:
 - (a) A clear and concise summary of the proposed approach
 - (b) A demonstrated understanding of the key objectives of the project An overview of the Responder's depth and breadth of similar experience
 - (c) A clear and concise understanding of the challenges of successfully implementing and operating an APCD within the State of Arkansas
 - (d) A description of the overall value that the Responder brings to the Arkansas APCD

G. Assumptions

The Responder must provide a list of all assumptions upon which the proposed solution and Project Implementation Schedule are based.

NOTE: HIRRD will only review proposals from bidders that demonstrate the minimum qualifications. HIRRD will consider proposals from bidders that fail to demonstrate minimum qualifications as non-responsive.

H. Minimum Requirements Narrative

Responder must document their ability, plans, and proposed processes for meeting the requirements, technical specification, deliverables, and timeline of this ITSC. Responders must provide clear responses to each requirement included in Sections 3.3, 3.4, 3.5, and 3.6. The narrative response to this section must not exceed 20 pages and must not include any pricing or cost information.

I. Data Models

- (1) In this section, Responders must provide a description of the data models that they will develop and implement for the data mart. HIRRD is specifically looking for a modeling style and functionality that is flexible, scalable, suitable for APCD reporting, appropriate for business intelligence user tools, and maximizes capacity at the best cost. Responders must provide two data models to show capability:
 - (a) A conceptual model for high level stakeholders and decision makers that will provide the major components and players of the system; and,

**HEALTH INSURANCE RATE REVIEW DIVISION - ARKANSAS INSURANCE DEPARTMENT
REQUEST FOR PROPOSAL**

(b) A logical data model that provides database and element descriptions, system connectivity, reporting and remediation.

(2) A sample logical data model is provided below. Responders must present their own version of the logical data model, optimized for reporting and analysis. The model should include all necessary components and layers; beginning from raw data submission, moving through the data cleansing process, into the final target schema, and ultimately into the reporting layer (if this layer is separate from the target schema). Responders must explain their approach and how this approach best supports the delivery of the end product. Responders must also explain how the model and the data submission process would be impacted if new data elements were added, and any limitations that may exist.

Sample APCD Data Model

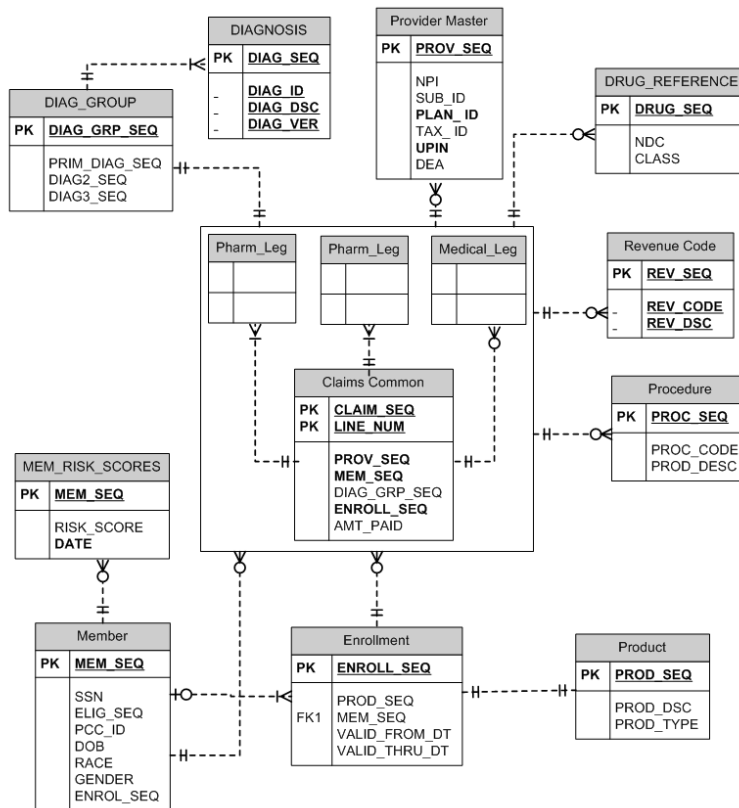

Notes:

- This sample logical data model is intended as an example only
- The Responder’s model must be designed and optimized for reporting and analytics

J. Response to Business Continuity Capabilities

In this section, Responder must provide a description of the capabilities, redundancies, disaster recovery plans, and safeguards for the Arkansas APCD data, of their proposed solution.

**HEALTH INSURANCE RATE REVIEW DIVISION - ARKANSAS INSURANCE DEPARTMENT
REQUEST FOR PROPOSAL**

K. Project Implementation Schedule

This section must provide a high-level description of the key activities, deliverables, and milestones that will be employed to successfully administer the project on schedule, and the Responders envisioned timeline for this project. The timeline must be based on the *Milestone Schedule in Section 3.7*.

Responder must identify critical dependencies and key risk factors in the work plan, and a plan for mitigating potential risks to the timeline. In addition, the Responder is asked to provide a Data Flow diagram, detailing the data collection and production process that they will implement as a part of their proposed solution.

L. Organizational Capacity

- (a) This section must detail the Responder's organizational capability to provide the scope of services described in this ITSC and be limited to 10 total pages. Description of the company, including when it was established, number of employees, locations of corporate offices, and which offices the staff that will be assigned to this project are affiliated with.
- (b) High-level description of the firm's organization, commitment to the public sector, and experience with similar types of project implementation.
- (c) State whether parts of the services proposed are to be provided by a Subcontractor and if so, describe the relationship with the proposed Subcontractor and the proposed Subcontractor's role during this engagement. In this section, Responders must provide a strong justification for choosing each particular Subcontractor, as well as provide examples of prior collaborations. Responders must also provide copies of any and all confidentiality agreements between them and the Subcontractor, pursuant to Section 1.7 of this ITSC. If more than one Subcontractor is used as part of the proposed solution, please provide information listed above (i.e. role during engagement, justification, examples of prior collaborations, confidentiality agreements) for all.
- (d) Detailed information on the hardware, software, communications, etc. infrastructure the Responder will utilize for the project
- (e) Demonstrate proficiency in data warehousing and hosting. If a separate hosting Subcontractor will be used, a detailed description of annual audits and reports regarding data center controls and operations, including Service Organization Control (SOC) Reports, Type 1 and Type 2, must be provided. If a separate hosting facility Subcontractor will not be used, Contractors must, at their cost, conduct an annual security assessment, performed by an independent third-party security provider, to verify that the environment containing the APCD data is secure. All test results, as well as remediation plans, must be submitted to HIRRD.

M. Relevant Experience and Expertise

- (1) Responder must describe their experience with three (3) prior (within the past five (5) years) or current projects with comparable scope, size, and complexity to this ITSC. Of these three (3) projects:
 - (a) One must demonstrate the Responder's experience creating and maintaining an APCD or a database of similar size and scope;

**HEALTH INSURANCE RATE REVIEW DIVISION - ARKANSAS INSURANCE DEPARTMENT
REQUEST FOR PROPOSAL**

- (b) One must demonstrate the Responder’s experience in collecting and integrating healthcare claims and eligibility data from multiple reporting entities (including commercial plans, third party administrators, pharmacy benefit managers, Medicaid managed care organization, Medicaid fee-for-service, Medicare, etc.) into a single warehouse;

Responders must document their experience using the structure below:

Client Name/Organization	
Example Type (A, B, or C from above)	
Client Size, Geographic Location, Industry	
Consumer Assistance Services Provided	
Technical Solution Provided	
Consumer Population Served	
Project Cost	
Project Start and End Dates	
Project Team Size	
Description of Project (250 words or less)	

(2) For Existing Data Centers in Arkansas

- (a) Describe the state of Arkansas’ current collection and/or use of health care data.
- (b) If multiple data centers exist in Arkansas, please indicate how the state prevents duplication and redundancy of efforts. Further, please describe statewide and regional efforts to integrate the data contained by different data centers.
- (c) If data is being currently collected on a voluntary basis, please describe this mechanism.
- (d) Describe any relevant statutory restrictions on proprietary or confidential data that may affect the dissemination of aggregated or disaggregated pricing data.
- (e) Describe the data elements collected (e.g. diagnosis codes, types of care, insurance product type, facility type, cost type, provider information).
- (f) Describe privacy and security practices and procedures designed to protect the data managed by the Data Center.
- (g) Describe current data release policies, as they apply to other government agencies, researchers, and other external parties.

**HEALTH INSURANCE RATE REVIEW DIVISION - ARKANSAS INSURANCE DEPARTMENT
REQUEST FOR PROPOSAL**

N. Responder References

Responder must provide contact information for three (3) client references drawn from the projects summarized in Section 0.2. The Responder must ensure that HIRRD is able to have appropriate access to the reference contact listed, and should expect that all reference contacts will be contacted. The three (3) references must be documented using the structure below:

Client Name/Organization	
Contact Name	
Contact Title and Project Role	
Phone Number	
Email	

O. Staffing Plan

The proposed project team must include individuals with substantial experience in the use of electronic health care claims data; working with integration and management of large data sets; quality assurance; data encryption; health care data privacy; data security; management of complex projects involving data collection from multiple organizations; web-based, public facing health data reporting; measurement calculations (NQF, HEDIS measures, etc.); and collaborative relationships with external data submitters. In this section, Responders must provide a summary of the proposed staffing plan, which identifies the number of staff, and key roles that will be required to support this project.

P. APCD Sustainability

- (1) HIRRD is looking for a Contractor to create a platform for financial sustainability. As part of this Proposal section, Responder should describe:
 - (a) The willingness and interest of the Responder to share resources in the pursuit of APCD self-sustainability and profit.
 - (b) The products and services that the APCD can offer to address the existing market opportunities (e.g. different types of datasets, licensing agreements, memberships, etc.).
 - (c) Which of these products and services the Responder would be able to provide.
 - (d) The estimated time and cost to produce each product or service.
 - (e) The ability and approach of the Responder to assist with marketing and distribution as related to the proposed data products and services.
 - (f) Any challenges that the Responder foresees in the creation and dissemination of data products.
- (2) Responses to this section shall not exceed 3 pages.

**HEALTH INSURANCE RATE REVIEW DIVISION - ARKANSAS INSURANCE DEPARTMENT
REQUEST FOR PROPOSAL**

4.3 Cost Proposal

This section describes the Cost Proposal submission requirement. Cost data will be examined after the Evaluation Committee has determined that the Responder's Proposal is fully compliant with the format and mandatory requirements of this ITSC. As mentioned previously, the total APCD ITSC award shall not exceed \$1.7 million.

The Responder shall provide a detailed Cost Proposal using the template in Appendix A as a point of reference. Cost Proposals shall:

- Contain separate prices for each task outlined, including separately identified costs for travel and per diem expenses;
- Distinguish between the fixed costs for the development, testing, and deployment of all APCD functions and components versus ongoing operational costs;
- Detail each project team member's hourly fees and hours associated with each Task on an annual basis;
- Not include any out of state travel expenses unless authorized to do so under resulting Contract;
- Include hourly rates for any work to be done under Subcontractor orders;
- Include pricing information for additional licensing, optional services, and dataset products, if any;
- Include a list of all assumptions upon which the Cost Proposal is based.

**HEALTH INSURANCE RATE REVIEW DIVISION - ARKANSAS INSURANCE DEPARTMENT
REQUEST FOR PROPOSAL**

**Appendix A – Cost Proposal Templates
Labor Rates Template**

Job Category nor Title*	Hourly Labor Rate (including Fringe Benefits) by Calendar Year			
	2013	2014	2015	2016
M1 - Project Manager	\$0.00	\$0.00	\$0.00	\$0.00
M2 – Privacy and Security Officer	\$0.00	\$0.00	\$0.00	\$0.00
E1 - System Architect/System Designer	\$0.00	\$0.00	\$0.00	\$0.00
E2 - Senior Software Engineer/Lead Developer	\$0.00	\$0.00	\$0.00	\$0.00
E3 - Software Developer/Engineer	\$0.00	\$0.00	\$0.00	\$0.00
E4 - Database Designer/Administrator	\$0.00	\$0.00	\$0.00	\$0.00
E5 - Network Administrator	\$0.00	\$0.00	\$0.00	\$0.00
E6 - GIS Analyst/Programmer	\$0.00	\$0.00	\$0.00	\$0.00
T1 - Software Testing Technician	\$0.00	\$0.00	\$0.00	\$0.00
T2 - Data Entry Technician	\$0.00	\$0.00	\$0.00	\$0.00
T3 - GIS Technician	\$0.00	\$0.00	\$0.00	\$0.00
S1 - System Trainer	\$0.00	\$0.00	\$0.00	\$0.00
S2 - Technical Writer/Editor	\$0.00	\$0.00	\$0.00	\$0.00
S3 - Administrative Assistant/Secretarial	\$0.00	\$0.00	\$0.00	\$0.00
Miscellaneous Job 1	\$0.00	\$0.00	\$0.00	\$0.00
Miscellaneous Job 2	\$0.00	\$0.00	\$0.00	\$0.00

* Key:

M = Management Level Position

E = Engineering

T = Technician

S = Support

**HEALTH INSURANCE RATE REVIEW DIVISION - ARKANSAS INSURANCE DEPARTMENT
REQUEST FOR PROPOSAL**

Task Cost Summary Template

Project Task Group from Scope of Services	Year 1	Year 2	Year 3	Task Totals
Tasks				
1. Planning				
Fixed Costs				
Labor Costs				\$0
2. Data Warehouse Services				
Fixed Costs				
Labor Costs				\$0
3. Data Collection Services				
Fixed Costs				
Labor Costs				\$0
4. Analytical Services and Value Adds				
Fixed Costs				
Labor Costs				\$0
5. Data Access				
Fixed Costs				
Labor Costs				\$0
6. Data Security				
Fixed Costs				
Labor Costs				\$0
7. Project Management				
Fixed Costs				
Labor Costs				\$0
Subtotal Tasks	\$0	\$0	\$0	\$0
Other				
Hardware Purchases				\$0
Equipment Leases/Maintenance				\$0
Commerical Software				\$0
Ongoing System Maintenance and Support				\$0
Travel				\$0
Misc. Office Expenses				\$0
Overhead (Indirects)				\$0
Other (Specify)				\$0
Subtotal Other	\$0	\$0	\$0	\$0
Annual Project Totals:	\$0	\$0	\$0	\$0